

- Innovative constructions
- Novel solutions
- Profitable products

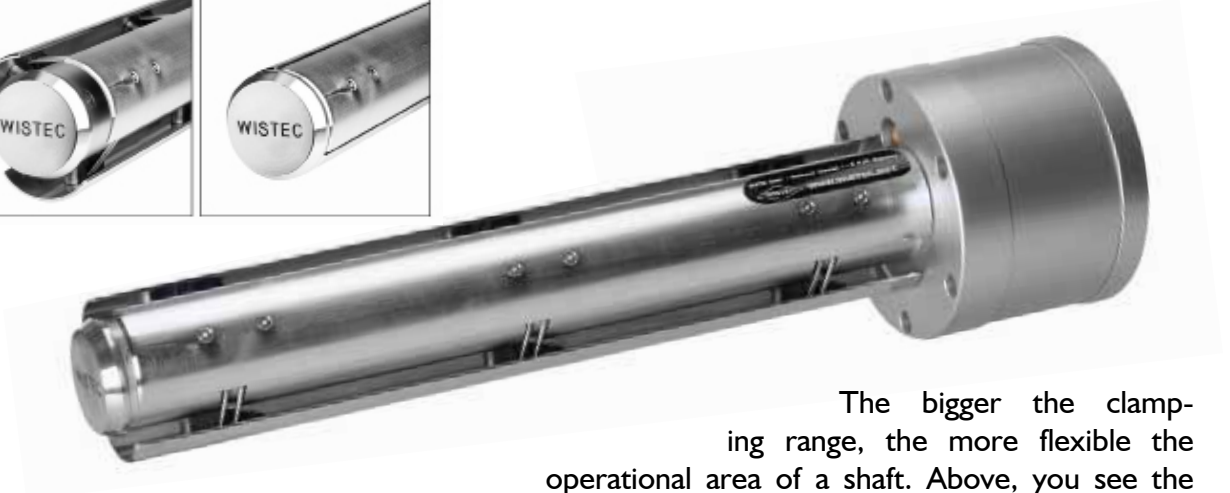

The bigger the clamping range, the more flexible the operational area of a shaft. Above, you see the field-tested solution for the size of 50-80 mm. We also offer well-engineered solutions for the range of 200-250mm and more.



Flange mounted shafts can be flexibly integrated into many system concepts. The version shown in the picture to the right brings the advantage of alignment of the web, for example by +/- 10mm.



You will receive a shaft with a flange bearing, ready to install. For easier removal of the cores, there are rolls between each SLAT.

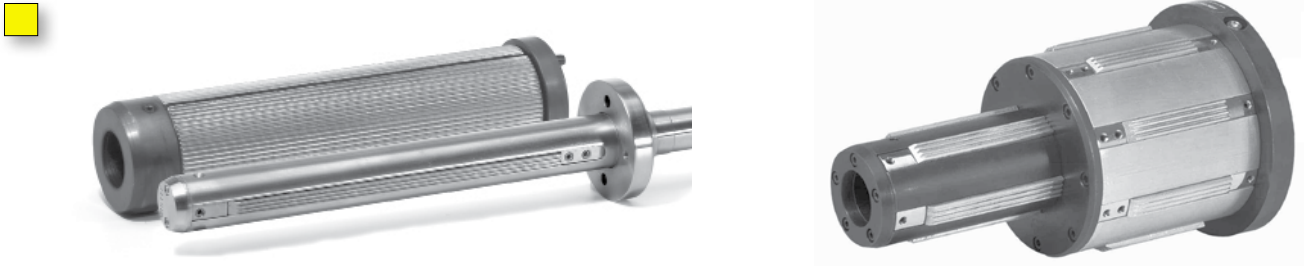

For every shaft, we offer a fitting adapter, which can either be activated mechanically by the shaft or by a compressed air supply.



When using this shaft, compressed air is only needed for a short amount of time. In addition to the security benefits, the pneumatic mechanical system ensures a 100% central positioning of the roll, even with high rollweights.

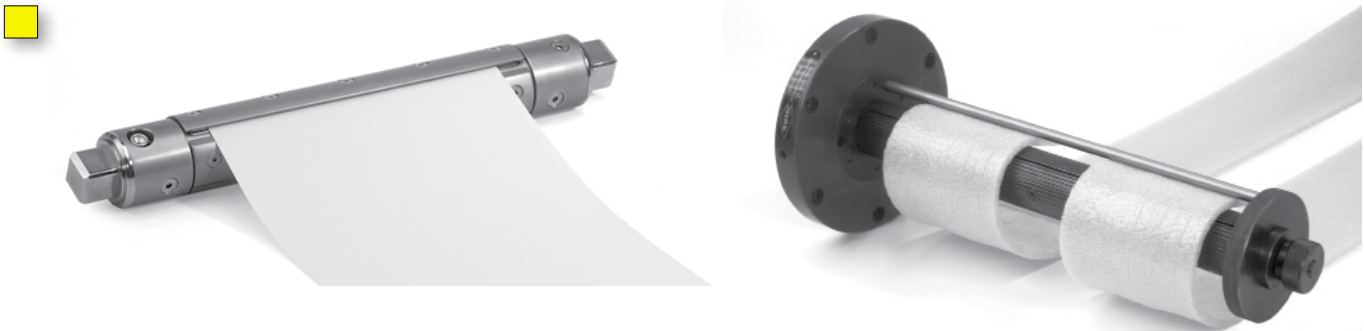

Since a lot of products can also be rolled without a core, we offer diverse shafts for core-less winding in order to minimize costs.



This would be a suitable solution when an axle free winding station is supposed to handle smaller rolls.