

The WISTEC Knifeholder 20-100 is appropriate for shear cuts of web materials. **The minimum cut width is 20 mm.**

TECHNICAL DATA:

Operating pressure:	3...6 bar
Total length:	300mm
Hub vertical:	20 mm
Hub horizontal:	2.5 mm
Circular blade:	100x70x1.2
Cutting angle:	0.5°
Weight:	1300g

The WISTEC Knifeholder 20-100 is an unusually durable and highly loadable mechanical component. It is torsionally stable and traces faithfully, characterized by the guidance of double ball-bearings. It possesses an integrated pneumatic control which ensures, as technical innovation, that the horizontal movement can only take place if the cutter head achieved its lower end position. Complex compressed air adjustment, a second compressor air port for the horizontal movement, or damaged knives by premature contact with the bottomknife belong in the past. The knifeholder is made out of rustproof materials, so all steel parts have an electroplated coating. The WISTEC Knifeholder 20-100 represents a flexible construction kit system. It can be adapted easily on existing guide rails. The knives can also deflect from used standards ($\text{Ø}100 \times \text{Ø}70 \times 1.2$ mm) without any problem. The WISTEC holder possesses a defined cutting angle. Nevertheless, you can easily use the second edge of the bottomknife by turning the cutter head around 180°.

WISTEC Knifeholder Type 20-100

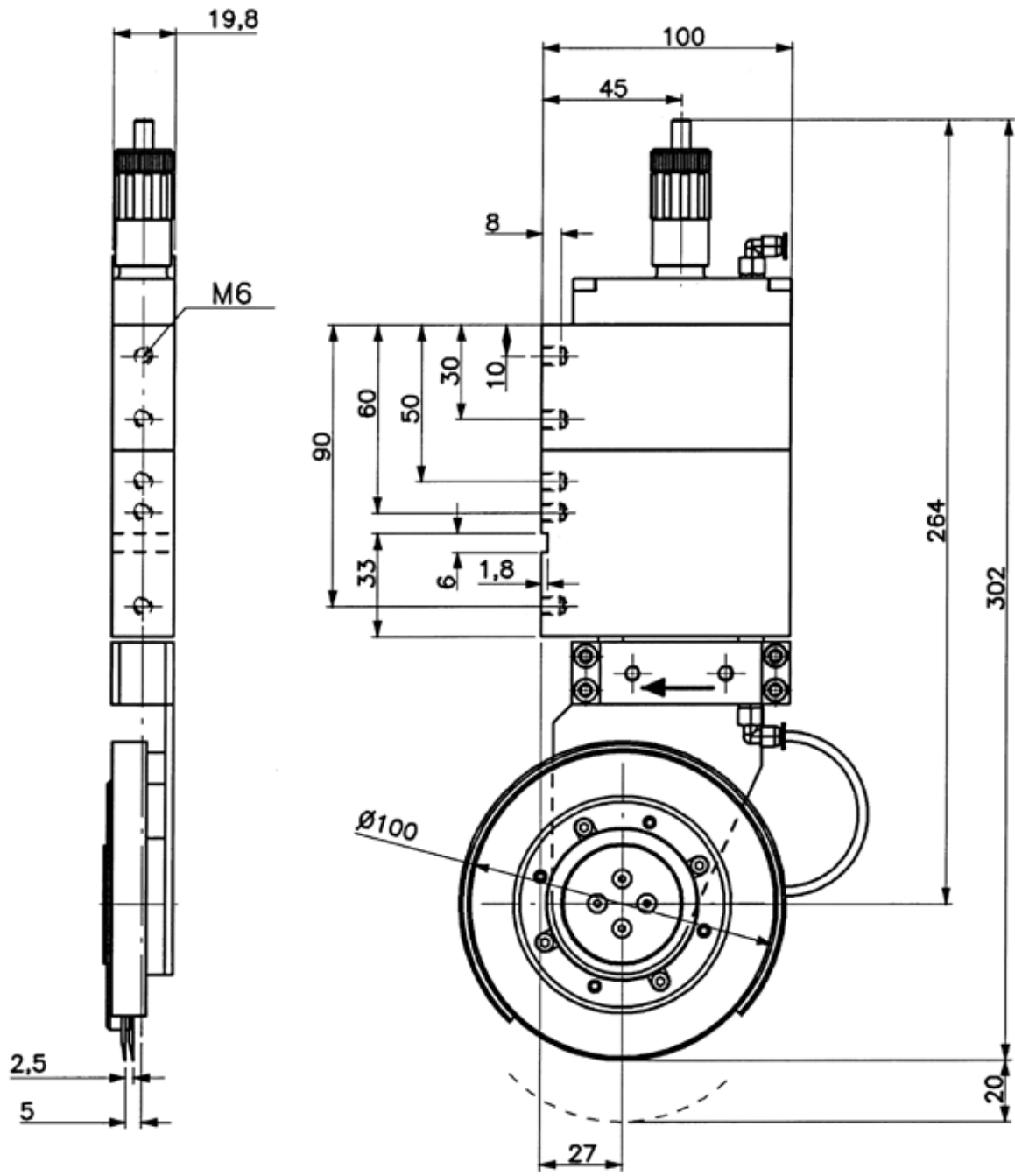

WISTEC GmbH Phone: +49-39888-525190 Fax: +49-39888-52744 E-mail: info@wistec.net	Knifeholder
	Type 20-100