

WISTEC

WISTEC Solutions for Winding and Slitting



www.wistec.net

Advanced Products for
Paper, Film and Foil Industry

PNEUMATIC EXPANDING SHAFTS

Type “K”

Pneumatic Shafts with LUGS

- Light aluminum constructions or solid steel shafts
- Version equipped with central hose
- Newly developed return spring for safe retracting

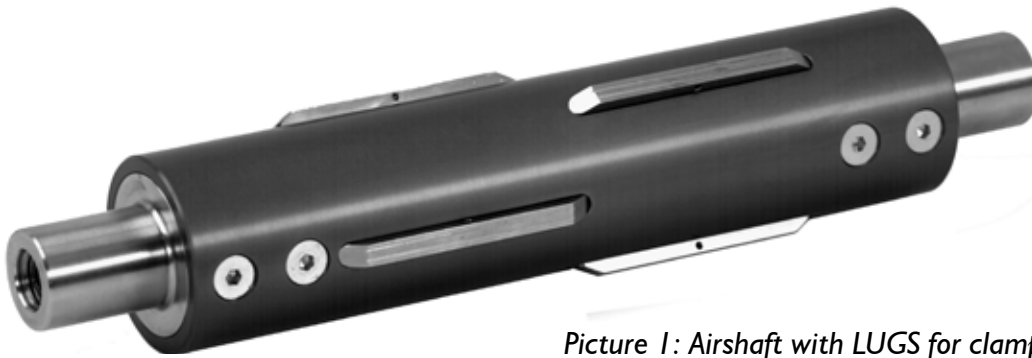

Picture 1: Airshaft with LUGS for clamping 70 and 76mm cores without having to modify the shaft itself.

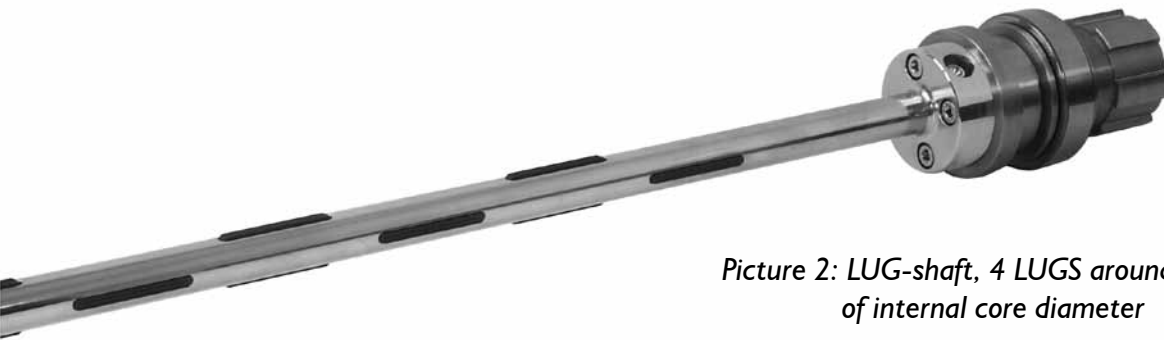

Picture 2: LUG-shaft, 4 LUGS around, for clamping 25mm of internal core diameter

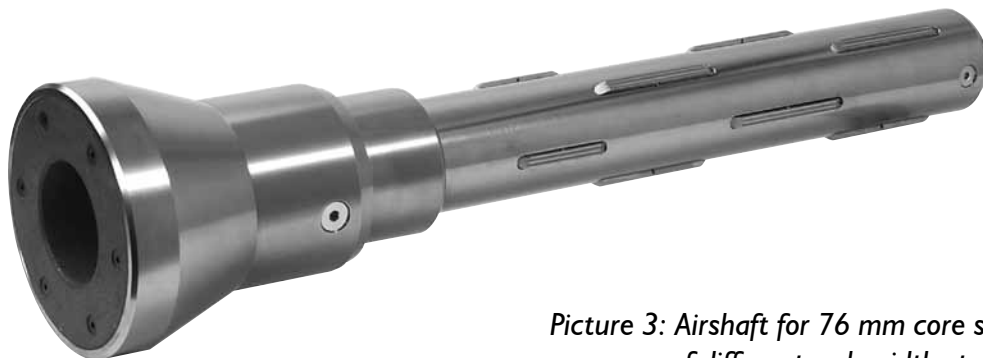

Picture 3: Airshaft for 76 mm core serves the adaptation of different web widths to axle free rollers

Type "S"

Pneumatic Shafts with LEAFS

- Gentle core clamping , especially when winding
- Good true-running characteristics
- Also designed for coreless winding



Picture 4: Flange mounted shaft with LEAFS



Picture 5: The product is safely gripped by a specially designed clamping LEAF.

Type "L"

Pneumatic Shafts with SLATS

- Resistant hoses out of polyurethane
- Light designed aluminum profiles
- Gummed SLATS for all core types



Picture 6: Flange mounted airshaft for 76 mm cores, 5 gummed slats on the surface

Picture 7:
Extruder shaft -
The body of the
shaft is pivoted



MECHANICAL EXPANDING SHAFTS



Picture 8:
Mechanical shaft with TAMBOUR-bearings, webspeed
>2500 rpm; lugs located with no spaces on surface



- 100% central role mounting
- designed for high speeds and sensitive materials
- expanded by all kinds of screw systems

Picture 9: Activation by wrench over hexagon in the shaftend

PNEUMATIC-MECHANICAL EXPANDING SHAFTS

- Combines the advantages of pneumatic and mechanical shafts
- Mechanical expanding - pneumatic loosening
- Constant grip reserve by the use of spring packs



Picture 10:
Pneumatic mechanical shaft for 150 and
152 mm cores, LUGS are overlapping

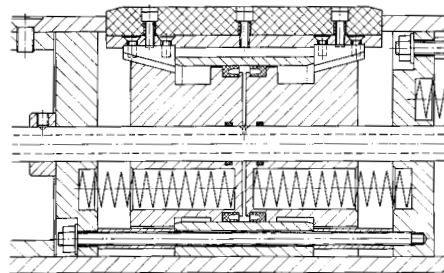

Picture 11:
Functional schematic of pneumatic-
mechanical shafts

PNEUMATIC-MECHANICAL CHUCKS



- Clamps 100% centrally with air pressure
- Standard version for 70 and 76 mm cores
- Double-stage chucks or adapters are an option for bigger core diameters

Picture 12: Standard chuck for 70 and 76 mm cores



Picture 13: Standard chuck with equipped adapter for 150 and 152 mm cores



Picture 14: Double-stage chuck for 70/76 and 150/152mm cores

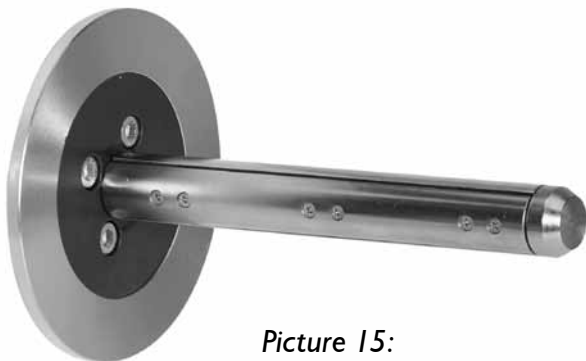

*Picture 15:
Pneumatic-mechanical
chuck with 3 centrally
working LEAFS, 20mm
internal core diameter*

Pneumatic-mechanical clamping is also possible with small internal core diameters, since the pneumatic drive can be outside of the actual clamping device.

All pneumatic-mechanical chucks can be built using two different designs:

- Clamp mechanically and loosen pneumatically
- Clamp pneumatically and loosen mechanically

PNEUMATIC CHUCKS



*Picture 16:
WISTEC adapter chucks for an internal core diameter of 150 and 152 mm, equipped onto a shaft for 76 mm cores. The advanced construction form of the chucks allows it to have a 15% higher torque transmission.*

*Picture 17:
Pneumatic chuck for 350mm internal core diameter, 16 SLATS on the surface*



*Picture 18:
Pneumatic chuck for 152 mm cores, flange-mounted version, central bolting is possible.*

IDLER ROLLS

We produce extremely light idler rolls out of the shown aluminum profiles.



All idler rolls can be produced with inside bearing, as well as with firmly used shaft ends for outside bearing.

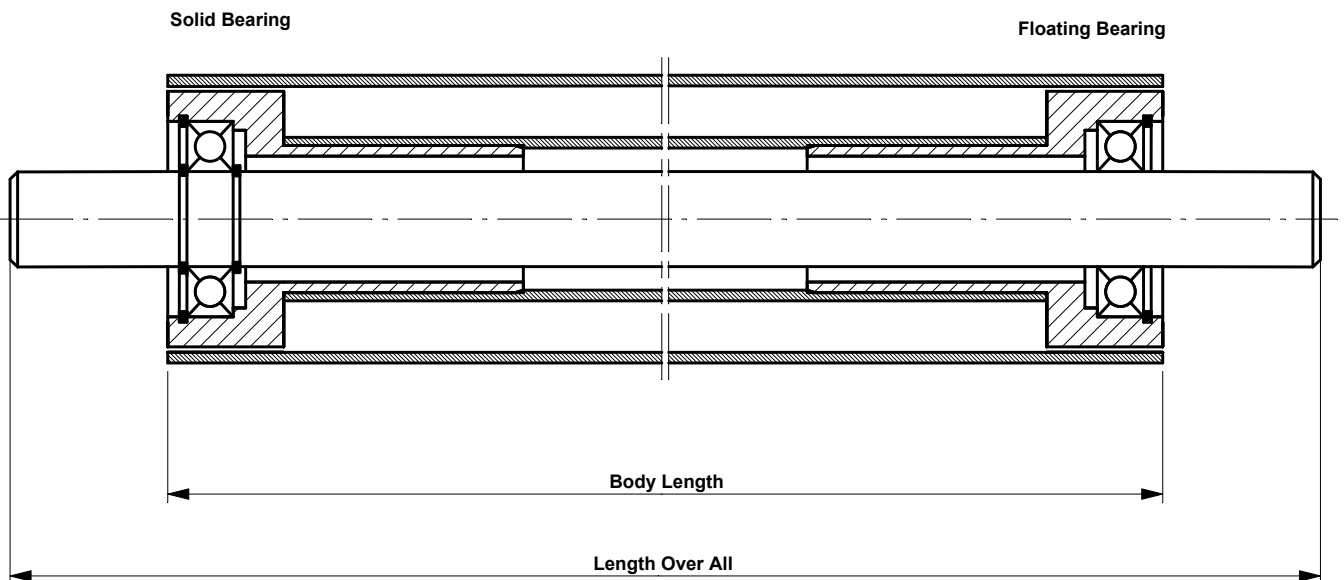

Picture 19: Idler roll with inside bearing

SLITTING SYSTEMS

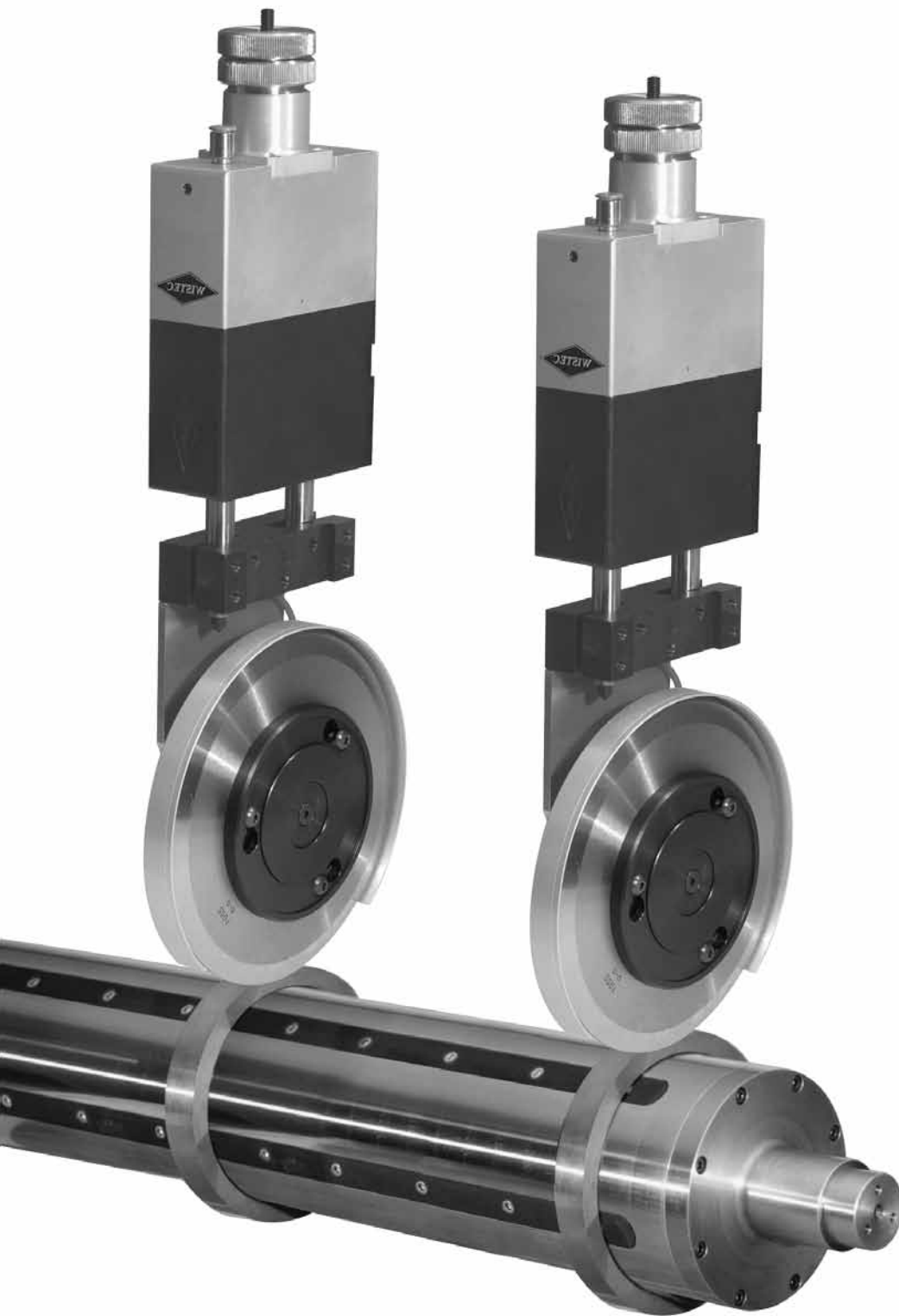

WISTEC slitting systems are designed for cutting the largest variety of materials, like paper, foils, laminate or non-woven products. The pneumatic knife-holders are designed and developed to set new standards.

You receive:

- Clean cutting edges
- Shorter changeover times
- Exact settings
- Very long knife lifetime

Picture 20:

Lengthwise cutting system, designed for shear cuts. Variable knife settings on the WISTEC pneumatic bottom knife shaft possible.

WISTEC GmbH
Winding and Slitting Technologies
Wustrower Chaussee 1
D-17255 Wesenberg, Germany

Phone: +49 39888 525190
Fax: +49 39888 527 44
E-Mail: info@wistec.net
Internet: www.wistec.net